

This drawing is protected by copyright and the design and or details contained therein are the confidential property of MAXWELL MARINE INTERNATIONAL LTD. This drawing must be returned upon demand and must not be copied, loaned or have its contents communicated to any other persons, including subcontractors, without the consent in writing from Maxwell Marine International Ltd. This drawing must not be used for any other purpose other than that for which it was originally supplied.

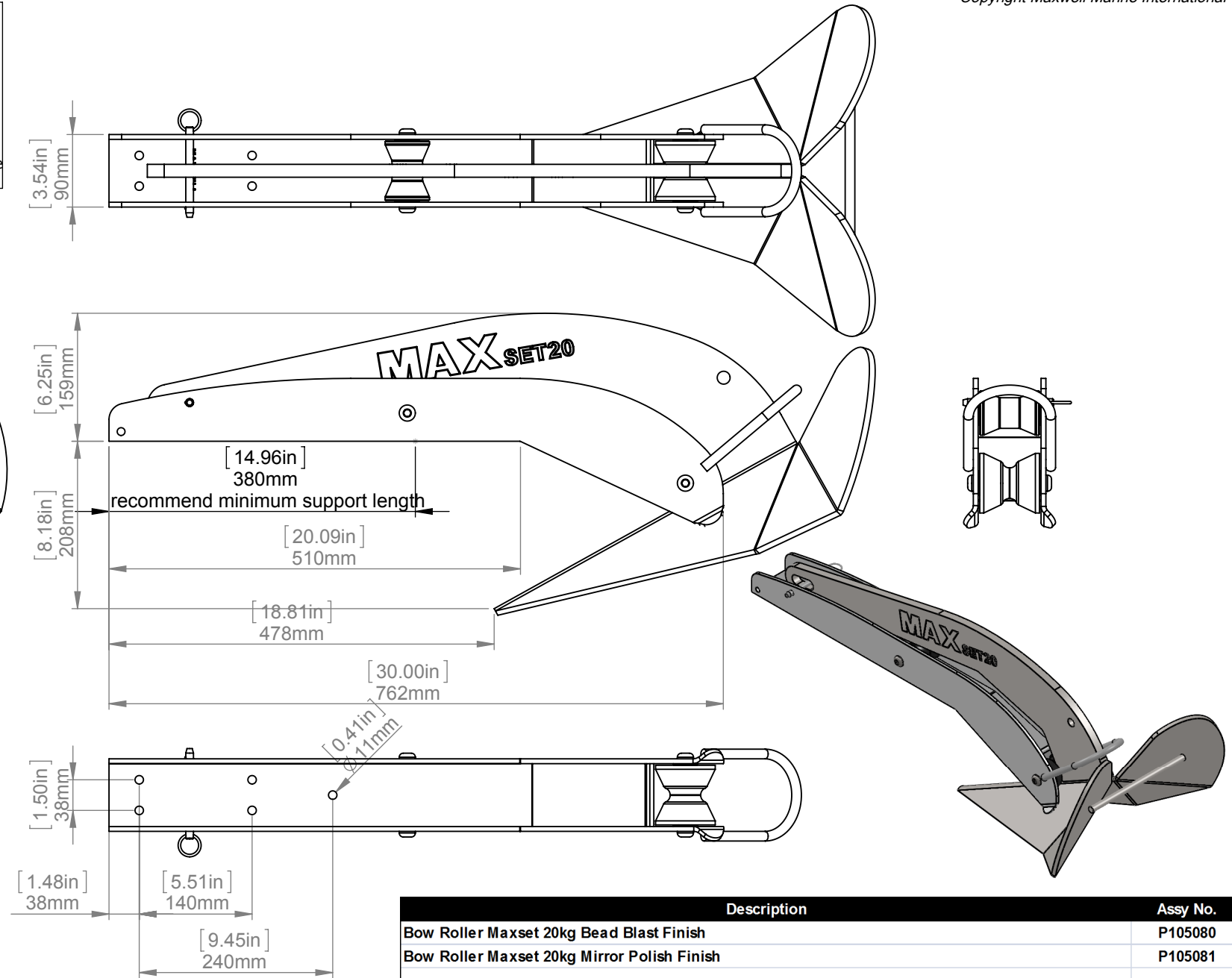
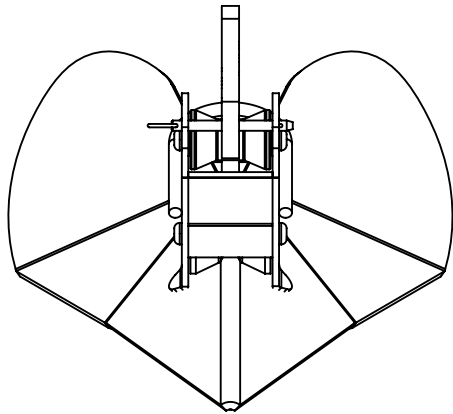

Description		Assy No.
Bow Roller Maxset 20kg Bead Blast Finish		P105080
Bow Roller Maxset 20kg Mirror Polish Finish		P105081

Rev.	Change	Made on	Des/Dwn	Checked
0.01	Initial Issue	14/07/14	Peter Chiu	CP
1.00	Update to Production version 1.00	08/09/14	Peter Chiu	CP

Sht Size	Scale	Dwg Type	Sheet	Description	Pbv/Dwg No.
A4	1:7	?	1 of 1	MAXset Bow Roller 16kg	P105080